

MADDEN

Metriflow Series

DIAPHRAGM METERING PUMP OPERATING MANUAL and PARTS LIST

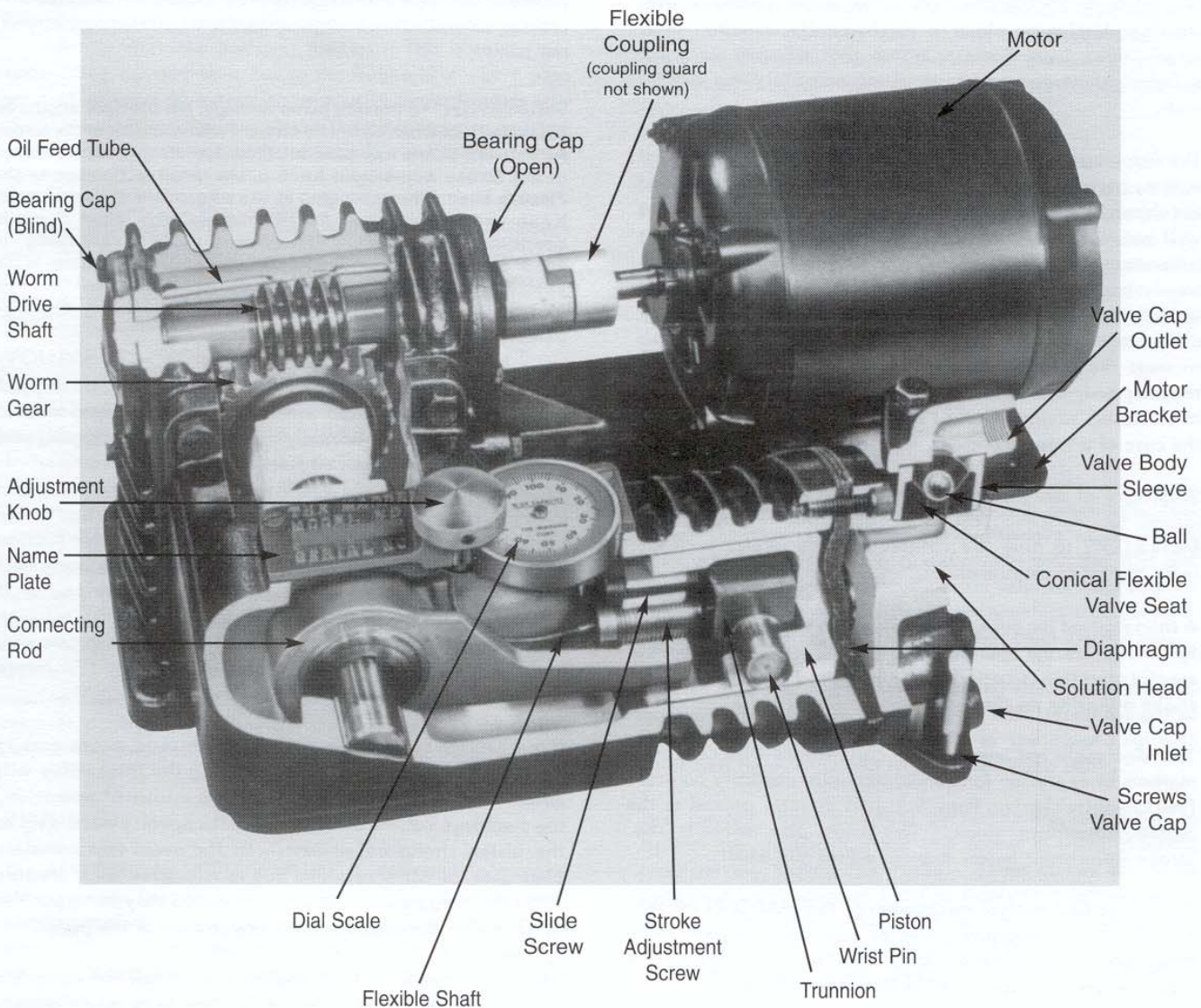

MADDEN

MANUFACTURING INC.

P.O. Box 387 • 1317 Princeton Blvd. • Elkhart, Indiana 46515

Phone (574) 295-4292 Fax (574) 295-7562

Email: maddenmfg@msn.com

Website: www.maddenmfg.com

The MADDEN METRIFLOW PUMP has been designed for the movement of chemical solutions and slurries of all kinds plus the additional advantage of a controlled volume discharge. It is built for heavy duty, continuous service. When operated according to the simple directions contained herein, it will require minimum attention.

Although the pump is simple in both design and structure, it embodies several features not encountered in other pumps. To obtain the best results it is important that the user fully understand the principle of operation and the function of the several parts.

THE OPERATING PRINCIPLE

The cut-away photograph, front cover, shows the heavy duty, flexible diaphragm which is mechanically actuated by a large, three inch diameter piston that operates with the extremely short maximum stroke of approximately one quarter inch.

The diaphragm, 1/4" thick and reinforced with four ply's of Nylon, has been imposed between the pump body proper and the chemical solution head to act as a tough, durable dividing wall between the pumping mechanism and the chemical solution to be transferred. The pump can thus be provided (or simply and economically changed at any time) to handle almost all chemical or abrasive solutions by simply installing a diaphragm, solution head and valves of the proper materials to meet the solution requirements. Thus, the materials in the pump body itself and the pumping mechanism are standard in all cases, saving needless original or rebuilding costs in the case of a later change in solution requirements.

Simplicity of design; rugged construction; total, self-contained lubrication all are built into the MADDEN METRIFLOW to give the longest possible service with the least amount of maintenance.

A short study of the cut-away photograph will help to quickly familiarize the operator with the METRIFLOW pump and special attention is called to the improved "Micro-Control" stroke adjusting mechanism.

The dial scale has one hundred calibrations with reference numbers at every ten for quick, accurate capacity control. (See Capacity chart on Page 5.) It is directly geared to the Stroke Adjustment Knob. This knob also controls the Stroke Adjustment Screw through a Flexible Shaft.

This simplified control mechanism of the MADDEN METRI- FLOW PUMP is practically free of wear because there is no movement except when a change in capacity is made. The "Micrometer" precision should last indefinitely.

With each revolution of the Eccentric, the Connecting Rod travels the full, maximum stroke along the two Slide Bolts.

"Lost Motion" space has been allowed between the forward end of the Connecting Rod and the Trunnion with the result that the movement of the Connecting Rod is not

transmitted to the Piston until the Stroke Adjustment Screw is advanced by rotating the Adjustment Knob clockwise. Further advancement progressively reduces the "lost motion" space, - thus transmitting an increasing portion of the Connecting Rod movement to the Piston. Final advancement will close the gap completely and the Piston will then travel full stroke and deliver the maximum discharge volume.

It should be remembered that, at any point above zero (on the dial scale), the Piston will always be fully returned on the back stroke by the action of the Connecting Rod against the heads of the two Slide Bolts, while the amount of forward movement will be governed by the position of the Stroke Adjustment Screw. Increased forward movement likewise increases volume of discharge up to the maximum capacity of the pump.

WARNING! To prevent pump damage, the operator should be cautioned that when complete forward advancement of the Stroke Adjustment Screw has been attained, further excessive rotation of the Stroke Adjustment Knob could result in damage to the Flexible Shaft. When changing stroke adjustment, the Adjustment Knob should be turned SLOWLY and ONLY when pump is operating. Always watch dial scale to avoid "overturning" in either direction. Turning the Adjustment Knob when pump is not operating could result in damage to the Flexible Shaft.

STARTING AND PRIMING

Each MADDEN METRIFLOW PUMP and Gear Case shipped from the factory is filled with the right amount and kind of lubricating oil and is ready for service when piping and power connections are completed.

When starting the pump it should be remembered that a few moments operation would be required to fill the solution section with fluid and displace all air present before the pump will become fully primed. When first put into service, or if allowed to operate without liquid entering the solution chamber, the air contained therein will tend to compress and expand with the movement of the piston and thus retard the flow and displacement of liquid.

If the solution supply is in such location as to assure gravity flow to the pump, the liquid entering the inlet valve will quickly displace the air and after a few moments' operation, the discharge volume should be at full capacity according to the piston stroke adjustment. In the event that complete clearance of air is retarded due to excessive backpressure at the discharge valve, the priming process may be expedited by relieving the pressure for a few strokes of the pump.

Whenever possible, it is desirable to install the pump and solution source in such relative position as to assure gravity - flow to the inlet valve. Inlet head pressure of several feet, or pounds will not interfere with the action of the valves or pump provided the discharge pressure, or backpressure at the discharge valve, is in excess of the inlet pressure. In any instance where the inlet pressure is equal to, or in excess of, backpressure at the discharge

valve, or where the supply source is at an elevation of one or more floors above the pump, it may be necessary to spring load the discharge valve to compensate for the unbalanced condition.

SUCTION LIFT

In some instances, individual conditions may make it necessary to install the pump at a point above, rather than below the solution supply, thus requiring a "suction lift" Although the MADDEN METRIFLOW PUMP is not intended for high vacuum service, it should be possible to obtain a lift of 6' to 10' when pump is in good working order.

In all instances where a suction lift is employed, it will be necessary to arrange means for priming the solution chamber in order to start the pumping process. This is easily accomplished by adding a tee to the intake line with a pipe spud of at least 6" extending vertically upward. This will expel the air in the chamber, avoid the churning due to compression and expansion and thereby enable the suction stroke to become effective.

In any service where "lift" rather than gravity flow is necessary, it is desirable to install a foot valve at the lowest point in the intake pipe to avoid losing the prime whenever the pump is out of service.

VOLUME CONTROL -See CAPACITY CHART page 5

The volume of fluid displaced is in proportion to the length of piston stroke. The length of stroke may be easily adjusted by turning the Stroke Adjustment Knob (on top of the pump). Turn clockwise to increase stroke (for *greater* volume) and counter clockwise to decrease.

The one hundred calibrations offer a high degree of adjusting accuracy plus simple operation and good visibility. Any change of stroke adjustment should be made slowly and always while pump is running. The operator should always watch the dial scale while making adjustment to avoid excessive "over-turning" at either end of scale, which could result in damage to the flexible shaft connection the Stroke Adjustment Knob with the Stroke Adjustment Screw.

DIAPHRAGM

The MADDEN METRIFLOW PUMP is designed to transfer almost every type and kind of fluid under many different conditions of volume, pH value, concentration, temperature, etc. Since there is no single substance for diaphragm use, which will withstand every service, it is necessary to select materials according to the work to be performed. Within the limitation of availability, we endeavor to furnish diaphragms, which will not only resist chemical attack, but will also have the required physical properties to assure long periods of service. We are constantly seeking new and better materials for the purpose and maintain extensive files of technical data pertaining to the properties of nearly all substances, which

may be usable. Such data is available to you in helping to solve individual problems.

No matter what material is employed, it must be remembered that diaphragms will eventually reach a point of fatigue when failure will occur. For example, with the motor driven units operating at 58 R. p .M .the diaphragm flexes 3480 times each hour or a total of 83,520 times for each 24 hour period. Although the diaphragm is supported by the contoured face of the piston, and the amount of flex or movement is distributed over a large area, the best materials will ultimately reach a point of fatigue. The useful life of a diaphragm will, of course, depend upon many different factors such as, the material used, chemical or physical attack, temperature of fluid, volume pumped, etc. It will be apparent that with full piston stroke the flex or movement of the diaphragm will be greater than for lesser loads and the life thereof will be reduced accordingly.

There is such a great diversity of service for the MADDEN METRI FLOW PUMP and so many different materials used that it is almost impossible to estimate the probable life period of diaphragms. A test pump transferring a non-abrasive, non-corrosive material and equipped with the standard Neoprene diaphragm ran at full stroke continuously, 24 hours a day, for over one year without showing any visible sign of diaphragm wear.

DIAPHRAGM- REPLACEMENT

When it becomes necessary to replace a diaphragm, first loosen the two valve cap screws and remove valves (Note: It may be necessary to first disconnect both the inlet and discharge lines). Next remove the six solution head screws. The old diaphragm may now be rotated counterclockwise until the screw mounting it to the piston has been disengaged.

Reverse this procedure when installing the new diaphragm, making sure to rotate it clockwise until screw has pulled the diaphragm snugly to the face of the piston, but with outer bolt holes matching the on the pump body.

The solution head can then be remounted, being sure to tighten the six socket head cap screws a little at a time progressively around the circle. These screws are to be tightened until solution head is firmly snugged up against the diaphragm, which, due to its resiliency, will bulge outward slightly. Do not greatly over tighten as pump capacity could be changed and diaphragm life could be lessened.

Remount valves, being sure to tighten the two through bolts alternately a little at a time so as to pull valve caps down evenly. Tighten only enough to prevent leaking and if gaskets have been badly compressed, replace with new ones.

CONTINUED ON PAGE 5



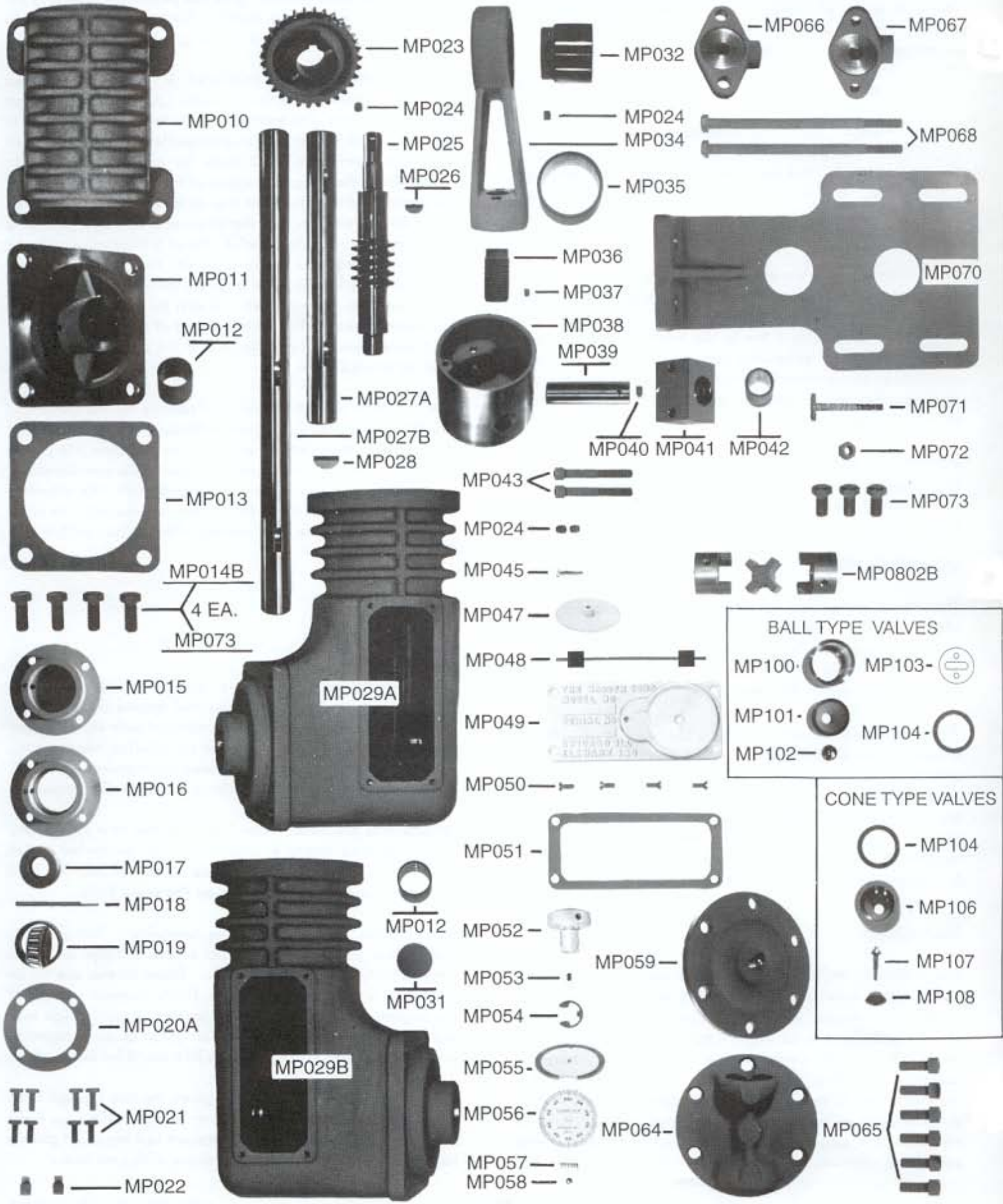

MADDEN *Metriflow* PUMP . . . PARTS LIST



BALL TYPE VALVES

MP100 - 	MP103 - 
MP101 - 	MP104 - 
MP102 - 	

CONE TYPE VALVES

	- MP104
	- MP106
	- MP107
	- MP108

PART NO.	NAME	REQ	PART NO.	NAME	REQ
MP010	Gear Case	1	MP048	Flexible Shaft	1
MP011	Side Flange-Gear Case	1	MP049	Name Plate	1
MP012	Bushing-Gear Case-Side Flange	1	MP049A	Name Plate Assembly	
MP013	Gaskets-Gear Case	2		M-45, 47, and M-49 through M-58	
MP014B	Screws-Gear Case	4	MP050	Screws-Name Plate	4
MP015	Bearing Cap (Blind) Gear Case	1	MP051	Gasket-Name Plate	1
MP016	Bearing Cap (Open) Gear Case	1	MP052	Adjustment Knob	1
MP017	Oil Seal-Gear Case-Bearing Cap	1	MP053	Set Screw-Adjustment Knob	2
MP018	Oil Feed Tube-Bearing Caps	2	MP054	Retaining Ring-Adjustment Knob	1
MP019	Timken Bearings-Bearing Caps	2	MP055	Dial Cover	1
MP020A	Gasket Set-Bearing Caps	2	MP056	Dial	1
MP021	Screws-Bearing Caps	8	MP057	Drag Spring	1
MP022	Oil Plugs-Gear Case	2	MP058	Drag Spring Ball	1
MP023	Worm Gear (Specify Pump Size)	1	MP059	Diaphragm (Specify Material)	1
MP024	Set Screw-Worm Gear	1	MP064	Solution Head-Metal (Specify Material)	1
MP025	Worm Drive Shaft (Specify Pump Size)	1	MP065	Screws-Solution Head	6
MP026	Woodruff Key-Worm Drive Shaft	1	MP066	Valve Cap-Outlet (Specify Size & Material)	1
MP027A	Pump Drive Shaft-Simplex	1	MP067	Valve Cap-Inlet (Specify Size & Material)	1
MP027B	Pump Drive Shaft-Duplex	1	MP068	Screws-Valve Cap (Specify Length)	2
MP028	Woodruff Key-Pump Drive Shaft	2	MP070	Motor Mounting Bracket	1
MP029B	Pump Body-Right Hand From Solution End	1	MP071	Support Screw-Motor Mtg. Bracket	1
MP029A	Pump Body-Left Hand From Solution End	1	MP072	Lock Nut-Support Screw	1
MP012	Bushings-Pump Body	3	MP073	Screws-Motor Mtg. Bracket	7
MP031	Expansion Plug	1	MP0802B	Coupling	1
MP032	Eccentric Drive	1	MP100	Valve Body Sleeve (Specify Material)	2
MP024	Set Screw-Eccentric Drive	1	MP101	Conical Flexible Valve Seat (Specify Material)	2
MP034	Connecting Rod	1	MP102	Valve Ball (Specify Material)	2
MP035	Bushing-Connecting Rod	1	MP103	Ball Cushion	2
MP036	Stroke Adjustment Screw	1	MP104	Gasket Valve, Top & Bottom	4
MP037	Set Screw-Stroke Adjustment Screw	1	MP106*	Valve Seat (Specify Material)	2
MP038	Piston	1	MP107*	Valve Stem with Nut (Specify Material)	2
MP039	Wrist Pin	1	MP108*	Flexible Valve Ring (Specify Material)	2
MP040	Set Screw-Wrist Pin	1	MP109	Spring Valve (Specify Material)	1
MP041	Trunnion	1	MP115	Valve Seat, Rigid (Specify Material)	2
MP042	Bushing-Trunnion	1	MP052A	O-Ring-Adjustment Knob	1
MP043	Slide Screws-Trunnion	2	MP082	Coupling Guard	1
MP024	Set Screws-Trunnion Slide Screws	4	MP083	Screw, Coupling Guard	2
MP045	Dial Cover Screw	1			
MP047	Dial Gear w/MP056 Scale	1			

* THESE PARTS REPLACE MP100 THROUGH MP103 IN SOME PUMPS.

MADDEN MANUFACTURING, INC. — 1317 PRINCETON BLVD. — ELKHART, IN

BE SURE TO GIVE PUMP MODEL AND SERIAL NUMBER WHEN ORDERING REPLACEMENT PARTS.



MP120 Solution Head Plastic-1 Req.



MP121 Face Flange-1 Req.



MP122 Face Flange Screws 6 Req.



MP123 Valve Connector-1 Req.



MP124 Valve Connector Flange Outlet-1 Req.



MP125 Valve Connector Flange Inlet-1 Req.



MP068C - 8" Valve Connector Flange Screws-2 Req.

TYPE DDB DOUBLE DIAPHRAGM PARTS

MP140 Diaphragm Spacer 1 Req.



MP134 Backup Diaphragm (Flat) 1 Req.



MP133 Screws-Solution Head 6 Req. (For PVC or Teflon Solution Head)
MP165 (For Metal Solution Head)

PIPE CONNECTIONS -Inlet and Outlet

The caps which hold the valves in place are tapped for 3/8" NPT pipe connections except for 90 GPH: 3/4" vertical.

VALVE STRUCTURE and ACTION

Ball valves are supplied as standard equipment with the MADDEN METRIFLOW PUMP. A special cone valve is also available for certain applications (See Parts List). With both types, the Inlet and discharge valves are Identical In size and structure and may be interchanged as desired. The caps incorporate the piping connection and replacement or cleaning is quickly done by simply removing the two valve cap screws. (Some installations may require disconnecting inlet and discharge lines.) When replacing screws, be sure to tighten alternately a little at a time so that caps remain parallel.

To insure a leak proof seal, gaskets are inserted at both top and bottom of valve body; these gaskets are made of a special material, which resists the action of almost every known substance. Whenever valves are disassembled, examine gaskets. If they have been substantially compressed replace with new ones rather than over tighten the two valve cap screws. Optional Teflon gaskets are also available.

Thousands of these valves are in service on Madden equipment pumping from heavy abrasive slurries to extremely corrosive fluids. Note the simplicity of this unique design. The removable seat has a conical shape and is molded from flexible materials such as Neoprene. The seat cushions the ball check and grips it to assure a positive seal. A sleeve encases and supports this flexible seat.

These valves offer much greater resistance to the cutting action of sharp abrasive materials because the resilient seat resists impingement better than hard materials such as stainless steel. The ball check will remain effective for a long period of time since it rotates in service with each closing.

Valve action governs the ability of a metering pump to perform within the minute tolerance of accuracy required.

LUBRICATING OIL

After a break-in period of 300 -500 hours, REPLACE OIL. Afterwards, It is suggested that the O11 be changed approximately every 3,000 -4,000 hours of normal operation. **REPLACEMENT OIL:** ISO 460 Grade Lubricating Oil, viscosity 2300 SSU at 100° F, paraffin based.

The oil drain plug is located near the bottom of the gear case at the rear, while the oil level plug is directly above it. With the OIL LEVEL PLUG removed, oil can be added or replaced until level reaches this hole, after which, the plug is replaced. **NEVER FILL COMPLETELY WITH OIL!**

For easy access to the pump cavity for oil fill or Inspection, remove the four screws holding the cover plate. Lift cover plate upward slightly and rotate 90 degrees, being careful not to damage the gasket. Continuous operation at low oil level or with contaminated oil will result in increased, bearing wear and early failure.

NOTE: It oil level is unusually high or low, turn off pump immediately. See paragraphs MD" and "E" on page 6.

BACK PRESSURE REQUIREMENTS

Your Metriflow pump requires a small amount of backpressure in the discharge line to quickly seat the check valve balls for accurate metering. If the discharge line does not have adequate back pressure, Install a check valve In the discharge line that will create 25 to 50 psi of back pressure, or install a spring loaded M200 valve on your pump.

PUMP REPAIRS

Complete repair service is available at the factory and at some local distributors. Repair instructions for your in-house repairs can be obtained from the factory.

CALIBRATION

The output of your pump is sensitive to several factors, which require you to calibrate your pump to determine the expected output at each dial setting. The viscosity of the fluid being pumped, backpressure on the discharge line, suction pressure or suction lift effect pump output. To calibrate the pump; 1) measure the amount of flow from either the suction end, or at the end of the discharge line, 2) measure the time it takes to pump the measured flow, 3) convert the output to gallons per hour, 4) record the output for all expected dial settings.

OUTPUT CHART -WATER @ 100 PSI

Model-GPH	5	10	18	36	60	90 ¥
Dial	GALLONS PER HOUR PER HEAD					
10	*	*	*	*	*	*
20	*	*	*	*	*	18.6
30	.5	*	1.6	3.8	3.6	23.1
40	.8	1.6	3.5	7.3	9.6	29.1
50	1.4	3.1	5.9	12.3	16.7	35.8
60	2.0	4.5	8.6	17.4	24.6	44.1
70	2.7	5.8	11.0	21.0	32.8	52.7
80	3.6	7.8	13.8	24.6	40.0	60.6
90	4.5	9.0	16.4	30.6	47.3	70.2
100	5.3	10.2	18.1	35.6	59.2	78.0

¥ - @ 5 PSI

Capacities given in chart are approximate. Minimal capacities are subject to variation.

TROUBLE SHOOTING GUIDE

PROBLEM	CHECKS and ADJUSTMENTS
<p style="text-align: center;">-A-</p> <p>Discharge from pump has stopped, reduced or become intermittent.</p>	<ol style="list-style-type: none"> 1. Supply line valve has been closed, or Adjustment Knob has been moved. 2. Adjustment Knob flexible shaft is broken. This allows knob to spin free and stroke adjusting screw to back off reducing output. Replace M-48 Flexible Shaft. 3. Supply or discharge line has become completely or partially clogged. 4. Obstruction in pump valves. Remove valve caps and clean valve seats of trash. Check for damage. Replace damaged parts. 5. Supply tank empty. 6. Possible air entrainment in supply line or pump. Bleed trapped air out. 7. Leak in supply line. 8. Lift of solution is in excess of pump vacuum capacity. 9. Ruptured diaphragm or broken diaphragm screw. Be sure to check for contamination of solution by pump lubricating oil - likewise for contamination of oil by solution. Replace diaphragm. A new diaphragm will require 24 -48 hours of break-in time until full rated output volume can be pumped. <p>Continuous operation of pump under these conditions could lead to Increased diaphragm or valve wear. In the case of No. 1,3 or 8, the pump may have been operating under excessive vacuum conditions and the diaphragm should be inspected for wear or possible rupture.</p>
<p style="text-align: center;">-B-</p> <p>Discharge volume greater than rated capacity.</p>	<ol style="list-style-type: none"> 1. If a new diaphragm has been recently installed, over tightening of the six solution head screws could result in excessive compression of the diaphragm. This distortion of the "working area" could give a slight capacity increase and might result in excessive diaphragm wear. 2. 2. Back pressure on the discharge line is too low. See page 5.
<p style="text-align: center;">-C-</p> <p>Pump drive motor has stopped although switch is on. NOTE: turn electrical current off immediately!</p>	<ol style="list-style-type: none"> 1. If discharge valve is shut off or discharge line should become clogged while pump is running, it will result in the suction stroke operating up to full capacity without a compensating discharge. The result will be excess pressure created during the power stroke of the piston. Overloading or "stalling" of the drive motor will quickly follow. If not properly fused, motor could burn out, excessive strain will be put on all working parts and the diaphragm could be badly weakened or ruptured. 2. Check for "normal" motor failure causes i.e.: faulty switches or wiring, blown fuses etc
<p style="text-align: center;">-D-</p> <p>Overflow of lubricating oil around Stroke Adjustment Knob and through air vent hole.</p>	<p>Pump body and gear case cavity is normally half filled with lubricating oil and overflow through the top of pump would be impossible. Check immediately for ruptured or leaking diaphragm. Contamination of oil by solution, solution by oil or both would follow. If oil is contaminated by a solution that is either abrasive or corrosive, serious damage to pump, gear case and all working parts of both could result.</p>
<p style="text-align: center;">-E-</p> <p>Drop in lubricating oil level.</p>	<ol style="list-style-type: none"> 1. Same as item "D". 2. 2. Leakage at oil plugs or oil seals.

****IMPORTANT****

The following section contains highly important information regarding the pumping of slurries of filter aids, diatomaceous earths and other suspensions of heavy solids. DO NOT INSTALL OR OPERATE PUMP until after reading this material.

The specific gravity of Diatomaceous Earths will vary to some extent according to grade and the method of processing, but in all instances it is in excess of 2.0 - or approximately twice the weight of water. Thus without constant agitation, the material will rapidly settle to the low point in tanks, containers, pipe lines, etc. It is important that the agitator in the slurry tank be in good working order at all times and the slurry sufficiently dilute to avoid any tendency for particles of earth to agglomerate or adhere to each other. As a general rule, 10% to 15% slurry solids by weight may be pumped successfully when suspended in water, but greater dilution may be necessary if the vehicle employed tends to be adhesive, "sticky", or of greater viscosity than water. This will also apply when equipment is operated in ambient temperatures lower than 60° to 70° F.

When installing pumps, it is well to remember that when the slurry leaves the tank and enters the connecting lines it is no longer subject to agitation, other than such turbulence as may be provided by the velocity of flow.

Therefore, for best operation, pump MUST be installed immediately adjacent to mixing tanks with connecting lines as short and direct as possible. ALSO it is equally important to use connecting tubes or pipe lines of suitable diameter for the operating conditions represented by each individual installation. Since turbulent flow in the lines is necessary to avoid precipitation of slurry solids, it will be apparent that the connections leading to and from the pump should be no larger than necessary to maintain reasonable velocities.

The type of slurry, size and concentration of solids, volume to be pumped, differential pressure, temperature, etc" all have a bearing upon the diameter and relative position of the lines connecting the pump, Because of the many variables as between one installation and another, it is not possible to specify here an exact rule pertaining to the size of connecting tubes or pipes which will apply in each and every instance, The table shown, however, will serve as a general guide and should be followed as nearly as possible for all ordinary installations.

RECOMMENDED SIZES OF CONNECTION LINES LEADING TO AND FROM SLURRY PUMP			
VOLUME PUMPED	2 to 8 – GPH.	9 to 19 – GPH.	20 to 60 – GPH.
Water Slurries or Similar Viscosity	3/16" I.D. Tube	1/4" to 5/16" I.D. Tube 1/8" to 1/4" Std. Pipe	5/16" to 3/8" I.D. Tube 1/4" to 3/8" Std. Pipe

DISCHARGE LINE FROM PUMP

The discharge line leading from the pump to the filter system should be of suitable size as recommended herein. It may extend from the pump at any angle from horizontal to upward vertical position, but should not extend downward from the pump.

This line should be as short and direct as conditions will permit, and free from upward or downward loops which might tend to trap either air or slurry solids. In any instance where long vertical lines are necessary, there will be a tendency to deposit slurry solids at the low point and possibly interfere with the action of the discharge valve.

SOLUTION CHAMBER

In all instances where the MADDEN METRIFLOW PUMP is in continuous operation, the flow velocity of fluid entering the bottom of the solution chamber will assure sufficient agitation to avoid excess precipitation of slurry solids. Whenever it is necessary to shut down or take the pump out of service for any considerable period of time -as at night, for example -the solids will, of course, tend to settle to the low point.

In those instances where dilute slurries are used, the precipitate will be relatively slight. When the pump is started, the velocity flow will usually provide sufficient agitation to clear the solution chamber. With heavy slurries,

however, or with pumps operated at very low discharge volume, it is recommended that the mixing tank, lines and solution chamber be completely drained and all solids flushed out BEFORE pump is shut down. This is the only SURE way to avoid precipitation of solids, with the resultant plugging of the system.

INLET LINE TO PUMP

In pumping slurries of suspended solids, it is always best to place the pump in such position as to assure gravity feed or so-called "flooded suction". It is also important to make sure that the discharge pressure is in excess of the inlet head, to insure proper seating of the valves. In any instance where such differential pressure does not exist, the condition may be easily corrected by means of spring-loading the discharge valve.

The connecting line to the pump inlet valve should be installed in the side of the slurry container, near but not at nor in, the bottom of the tank. This line should be of recommended size and may be in either horizontal or vertical position, provided the vertical run extends upward from the pump valve. If extended downward, more or less air will enter the solution chamber and interfere with the accuracy of the pump. Be sure this line is of suitable size for the service required, and free from loops or bends which might serve to trap either air or slurry solids.