

MADDEN Manufacturing, Inc.

\$\$ High boiler fuel bills getting you down? \$\$
Madden boiler continuous blowdown heat recovery systems deliver BIG FUEL SAVINGS fast!

Over 50 years of delivering fuel savings. Here's a typical example:

Number of boilers:	3	f. Hot water after flash:	3,280 PPH
Total steam capacity:	90,000 PPH	g. Heat recovery, hot water:	459,200 BTU/HRh. Combined total recovery
Operating pressure:	200 psig	(e + g):	1,290,800 BTU/HR
Average steam generation:	50,000 PPH		

a. Avg continuous blowdown: 4,000 PPH
 b. Flash steam pressure: 5 psig
 c. Flash steam produced: 720 PPH
 d. Heat in flash steam: 1,155 BTU/LB
 e. Heat recovery, steam: 831,600 BTU/HR

FUEL SAVINGS

i. Fuel saved: 16.14 Therms/HR
 j. Cost per Therm: \$0.60
 k. Savings per day: \$232.34
l. Savings per year: \$84,806

Why Madden?

Madden blowdown heat recovery systems are designed to be simple and rugged. No sediment accumulation, no scaling. Twenty standard models with capacity ranging from 1,200 PPH up to our largest standard model with 50,000 PPH of blowdown capacity.

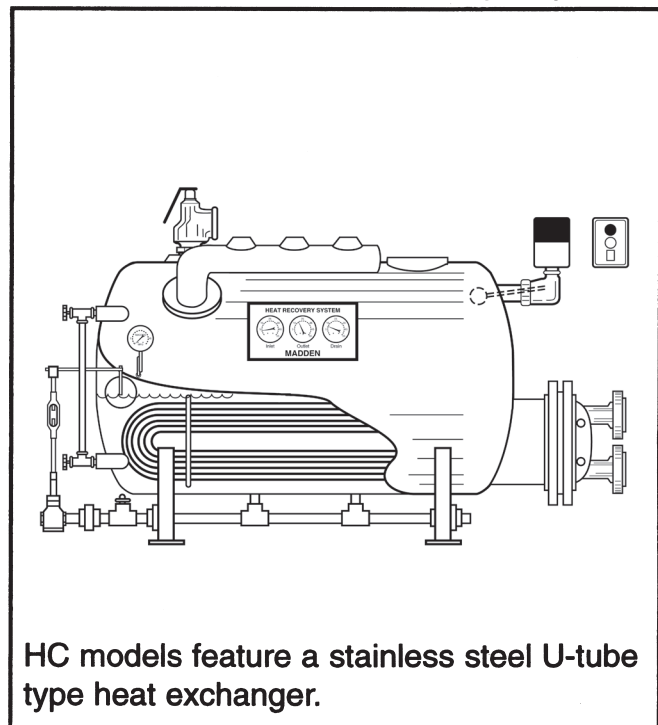
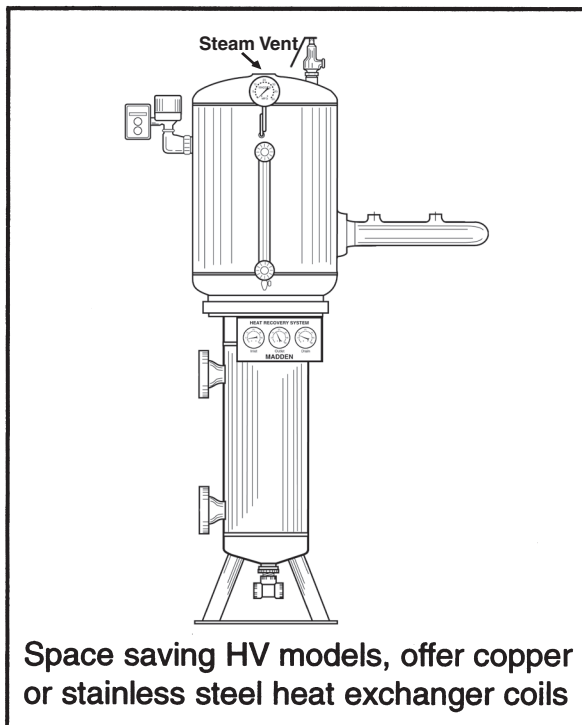

Boiler System Equipment

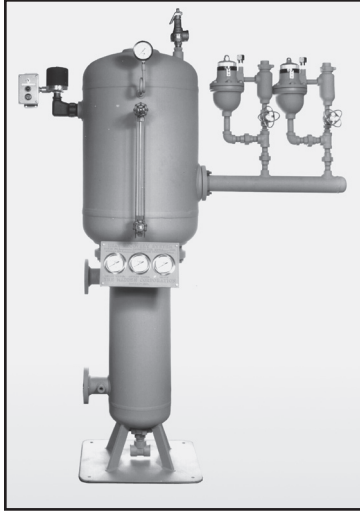

Continuous Boiler Blowdown Heat Recovery Systems

- Recovers 90% of heat that may be lost from continuous top blowdown flow.
- Pays for itself in a matter of months.
- Compact and durable for years of tough service with minimal attention to repairs.
- Complete with drain valve, heat exchanger, flash tank relief valve and gauges.
- 3 different styles to choose from.
- 20 standard models from 1,200 to 50,000 PPH of blowdown flow.
- Hundreds in service, for over 50 years.
- See brochure HX06

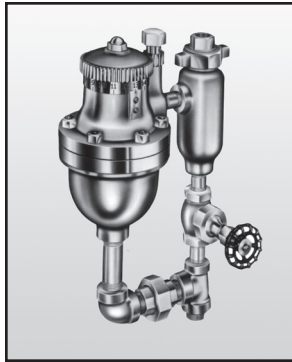

Orifice Meter for Boiler Continuous Blowdown Flow Control

- Precise, repeatable flow control of hot, dirty top blowdown water.
- Two models, 250 psi and 650 psi.
- 17 different set points to control blowdown flow.
- Built-in strainer and flush valve.
- Stays accurate for a minimum of 10 years.
- Better control reduces chemical costs and improves water and steam quality.
- See brochure OM99.

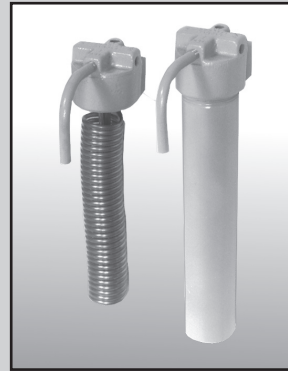

Sample Coolers

- Cools hot condensate and blowdown water so chemical analysis and instrument monitoring can be done.
- Ten models, up to 5,000 psi coil rating.
- Copper and stainless steel coils.
- Durable, repairable.
- See Data Sheet SC10 for details.

Bottom Boiler Blowdown Flash Tanks, Separators and After Coolers

- Rugged equipment to cool intermittent boiler blowdown for discharge to sewer systems
- Enables operator to meet thermal discharge limits
- Standard systems for boilers up to 300 psi include flash separator, aftercooler, temperature gauge and temperature activated cooling water valve
- Custom engineered systems to customer's conditions or specification, see brochure BDS01

MADDEN Manufacturing, Inc.

P.O. Box 387 • Elkhart, Indiana 46515
Phone 574-295-4292 • 1-800-369-6233
Fax 574-295-7562
e-mail: info@maddenmfg.com

Sold By

Website: www.maddenmfg.com